

# Self Actuated Thermostatic Valves

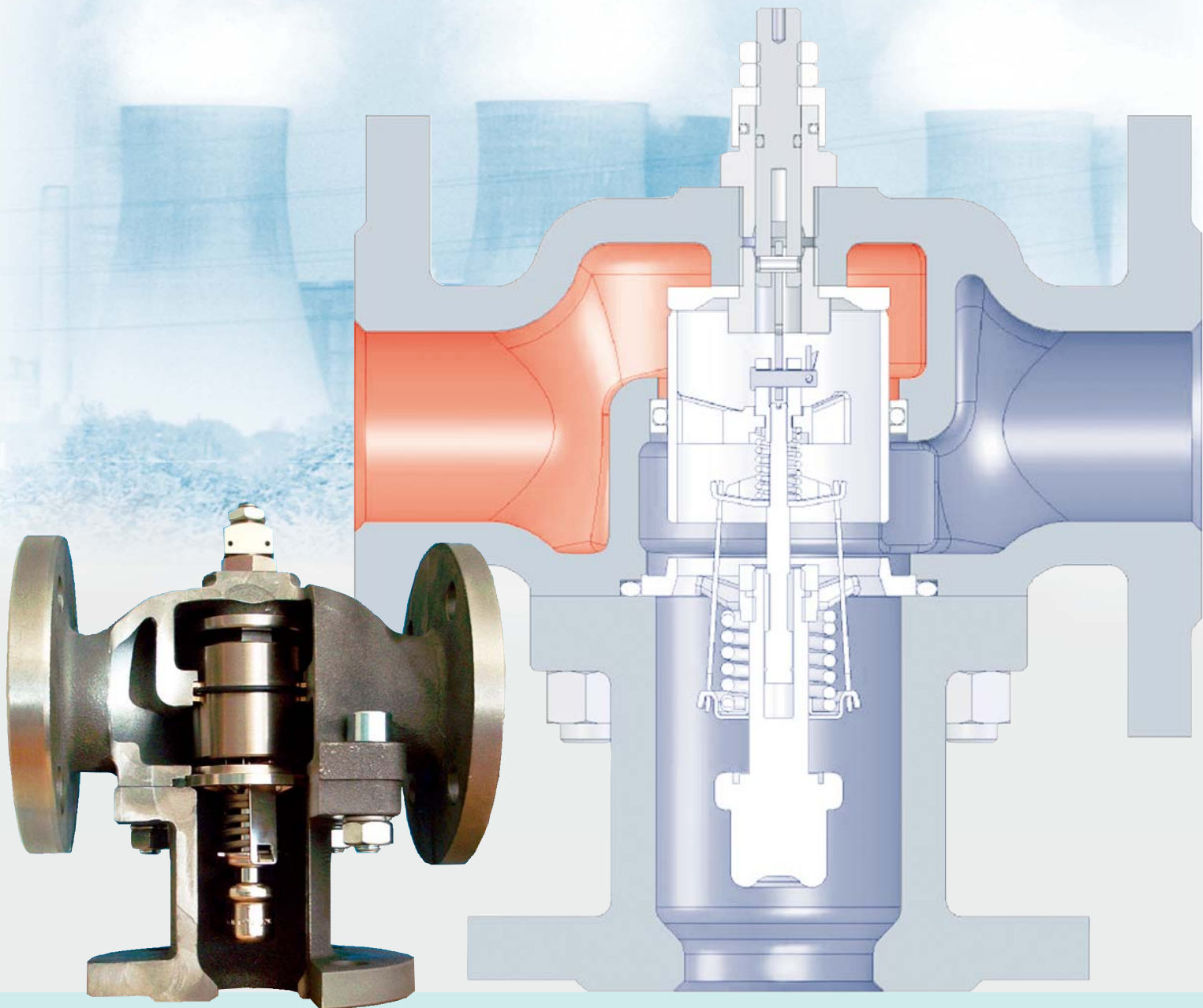

MVA Mess- und Verfahrenstechnik GmbH  
Am Kirchenhölzl 7 • D-82166 Gräfelfing  
Fon: +49/89-85 83 69-0 • Fax: +49/89-85 83 69-70  
info@mva-messvt.de • www.mva-messvt.de



Automatically operated without external power for process control applications

The Expertise for Components

# SELF ACTUATED THERMOSTATIC VALVES

2

Temperature regulation of lubrication and cooling loops with oil or water and solar systems for the following applications

MVA offers a wide range of automatically operated thermostatic control valves for mixing and bypass loops. All valves are equipped with fully automatic working elements based on the wax expansion principle and provide most reliable and approved components for process control applications since decades.

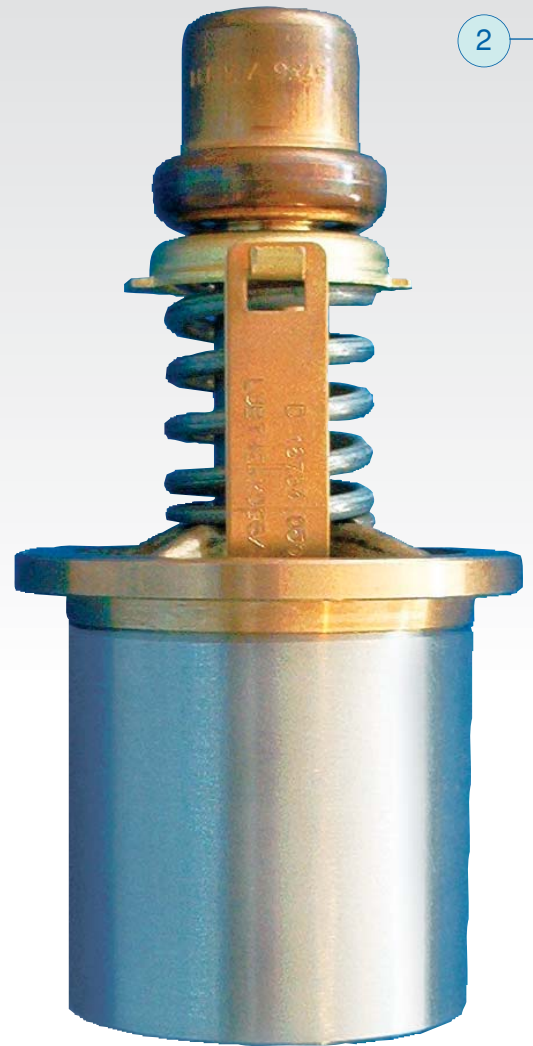
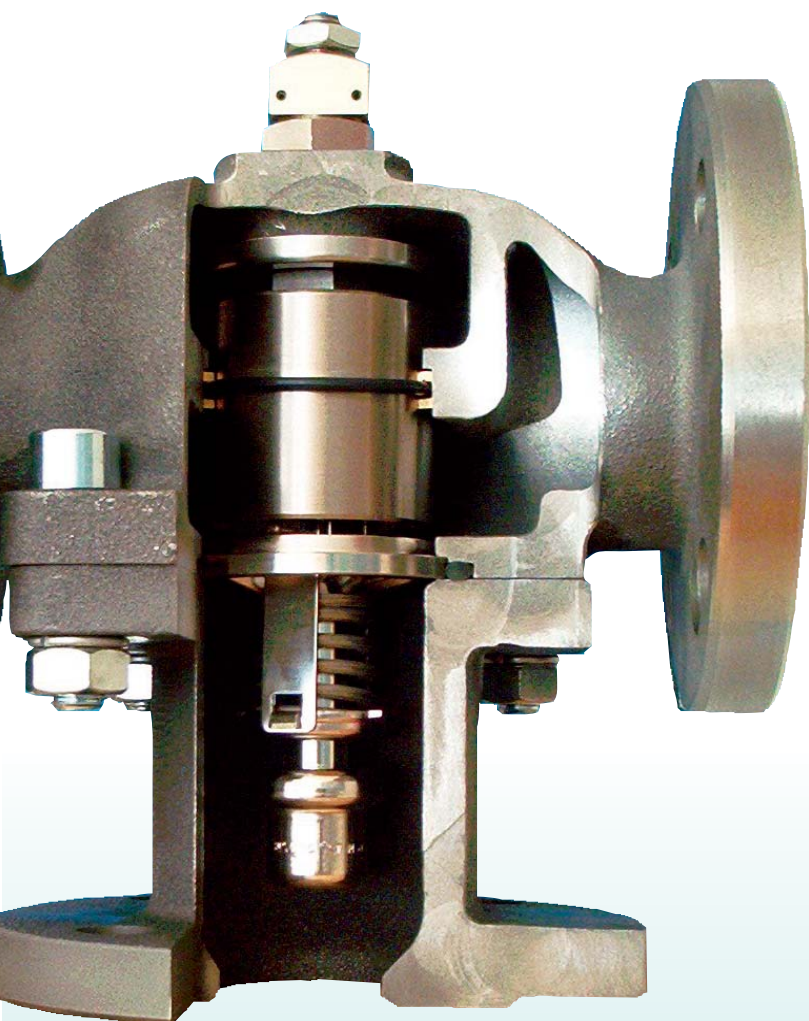

## Applications:

- Compressors
- Diesel engines
- Gearboxes
- Steam turbines
- Gas turbines
- Refrigeration systems
- Solar systems

## Sizes:

DN 20 - 40  
Threaded Connections  
3/4" - 1 1/2"  
DN 20 - 150  
Flanges according  
to DIN or ANSI

## Flowrates:

2 to 320 m<sup>3</sup>/h

## Body Material:

Cast Iron, Graphite Iron,  
Cast Steel, Aluminium,  
Bronze, Stainless Steel

## Nominal Temperatures:

+13°C bis +116°C

## Special Features:

Kanigen Plated Elements,  
PTFE Sealings,  
Manual Override

MVA Thermostatic Valves are used to provide reliable, automatic control of fluid temperatures in turbines, compressors and engine water jacket and lubricating oil cooling systems. They are also suitable for process control and industrial applications where fluids must be mixed or diverted depending on their temperatures. They may also be applied to co-generation systems to control temperatures in the heat recovery loop assuring proper engine cooling and maximising heat recovery.

All MVA Thermostatic Valves are equipped with positive 3-way valve action in which the water or lubricating oil is positively made to flow in the direction required. On jacket water applications when the engine is started up and is cold, the MVA Thermostatic Valve causes all of the water to be positively by-passed back into the engine, thus providing the quickest warm-up period possible. After warm up, the correct amount of water is by-passed and automatically mixed with the cold water returning from the heat exchanger or other cooling device to produce the desired jacket water outlet temperature. If ever required, the MVA Thermostatic Valve will shut off positively on the by-pass line for maximum cooling. The 3-way action of the MVA Thermostatic Valve allows a constant volume of water through the pump and engine at all times with no pump restriction when the engine is cold.

## ADJUSTMENTS & MAINTENANCE

No adjustments are ever required on MVA Thermostatic Valves. Once installed a MVA Thermostatic Valve will provide years of trouble-free service.

## TEMPERATURE SETTINGS

Because MVA Thermostatic Valves are set to a pre-determined temperature at the factory, costly errors due to mistakes of operating personnel are eliminated. After a MVA Thermostatic Valve has been installed, it is impossible for the operator to arbitrarily change the operating temperature and run the engine too cold or too hot unless the temperature element assemblies themselves are changed.

MVA Thermostatic Valves are temperature rated for the expected nominal operating temperature in jacket water service. On lubricating oil applications the system operating temperature may be slightly above the nominal rating, depending on the type of oil flow rate, oil cooler capacity and other conditions of the system.

For long life, MVA Thermostatic Valves should not be operated continuously at temperatures more than about 54° F (12°C) above their nominal ratings. If higher continuous over-temperatures are expected, contact the factory for recommendations.

## OPERATION

The power creating medium utilises the expansion of a special thermostatic wax material which remains in a semi-solid form and which is highly sensitive to temperature changes.

INSTRUCTIONS FOR MVA TEMPERATURE VALVE MODEL "M" WITH AND WITHOUT MANUAL OVER-RIDE

### 1) Maintenance

Properly applied and installed, MVA Thermostatic Valves require minimal maintenance. An inspection at 2 or 3 year intervals is adequate to detect and make provision for manual wear.

Excessive temperatures, chemical, electrolytic attack or cavitation will shorten the life of the element assemblies, seals and seats. These items are replaceable. Water additives may cause swelling of the O-ring seals around the stem and the sliding valve to a point where they may affect valve action and require replacement. Synthetic base lubricants will definitely attack the O-ring seals which may be replaced by O-rings of alternate materials. Contact the MVA factory for recommendations.

Carbonates, scale and other solids must not be permitted to build up on sliding valve or sensing cup surfaces. The valve and element assemblies may be cleaned with mild acid or Oakite solutions. Hard scale may require wire brush buffing.



## 2) Manual override

If for any reason "M"-Thermostatic valves with manual override should not work properly, each element assembly is fitted with an infinitely variable override which allows on accurate manual temperature regulation.

Before the manual override is used we recommend, however, to check whether the cause of trouble is not somewhere in the system, according to paragraph 3) "Trouble shooting". Manual override should only be used in emergency case.

If a thermostatic valve with several element assemblies is installed (DN 65 - DN 125) it is recommended to open one element assembly after the other against cooler by turning screw until desired temperature is nearly reached. Final regulation is done with next element assembly.

## 3) Trouble-Shooting

In the event that your cooling system does not operate close to the desired temperature, the following check list may point to one or more causes for the problem.

### 3.1 System Temperature too cold

- a) Insufficient heat rejected to coolant to maintain the temperature
- b) Wrong nominal temperature selected
- c) Thermostatic valve is greatly oversized for the system flow rate or cooling capacity of the system is much greater than is required
- d) Thermostatic valve is installed backwards, forces water to cooler and causes engine to run cold under all conditions
- e) Worn O-ring seal around the element assembly
- f) Too great a pressure difference (in excess 1,7 bar) between ports 2 and 3
- g) Foreign material is stuck between sliding valve and seat
- h) Element assembly may have been over-temperated sufficiently to affect calibration or rupture wax seal and does therefore not close "2"-port completely anymore. Requires complete new element assembly.

### 3.2 System Temperature too hot

- a) Cooling capacity of system not adequate
- b) Thermostatic valve too small for flow rate (also causes high pressure drop and possibly cavitation)
- c) Valve installed backwards; as temperature increases, Port 2 closes, reducing flow to cooler
- d) Bypass will not close due to worn or pitted seats, sliding valve, O-ring seal, etc.
- e) Worn O-ring seal around the element assembly
- f) Element assembly may have been over-temperated sufficiently to affect calibration or rupture wax seal and does therefore not fully open "3"-port anymore. Requires complete new element assembly.
- g) Solids build up on sliding valve prevents proper action of element assembly
- h) Foreign material stuck between sliding valve and seat
- i) Excessive pressure differential between port (very low pressure through bypass leg, very high pressure in cooler)

### 3.3 Additional Considerations

- a) Thermometers: A thermometer that reads the same whether system is cold or hot needs replacing
- b) Location of thermometers: on horizontal pipe runs, these should be in the side of the pipe when possible, particularly on oil systems. Also, pipes do not always run full so the thermometer may not be immersed in the fluid
- c) Thermometers should be as far as possible downstream from the confluence of two streams of different temperature to allow complete mixing
- d) Look for bypasses or "sneak circuits" which prevent thermostatic valve control of the complete system

**Fig. 1 COOLING WATER-HEAT EXCHANGER**

This scheme shows the cooling water circuit of a fix installed or a ship engine with cooling by a heat exchanger. The MVA Thermostatic Valve is in such a way installed, that the temperature of the cooling water at the outlet of the engine will be maintained constant. Should exist any problem cause by enclosed air, a narrow ventilation pipe (x) leading from the highest point of the system to the compensation tank will help.

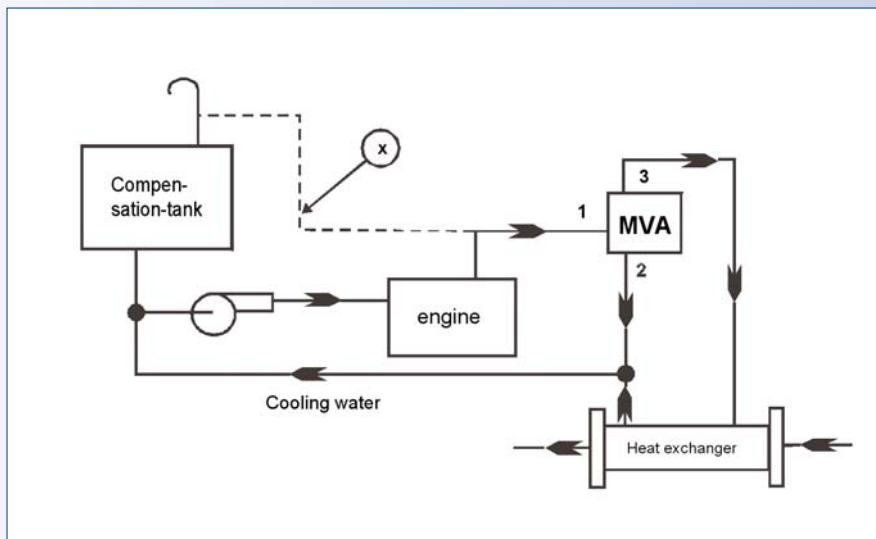

**Fig. 2 COOLING WATER-AIR COOLING DEVICE**

This arrangement is used practically always in vehicles and fixed installed engines with air cooling device. Here, the temperature of the cooling water also will be maintained constant at the outlet of the engine.

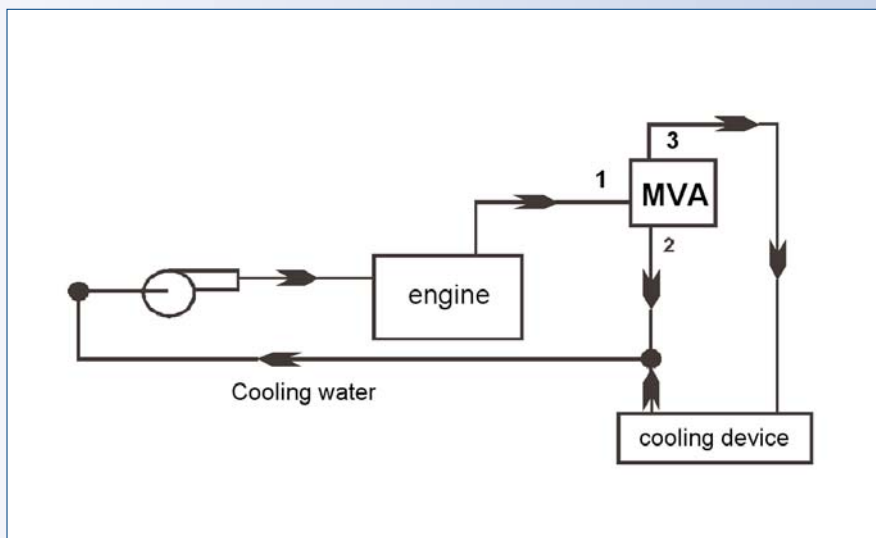

**Fig. 3 COOLING WATER – DIRECT COOLING**

Today, small and medium size engines are partially still cooled directly by sea water, although the disadvantages of such systems are well known.

In Fig. 3 the temperature of the cooling water is maintained constant at the engine's outlet. If the point T is above the water line, a non-return-valve (W) must be installed, in order to avoid that the cooling system loses all its fluid if the engine is stopped.

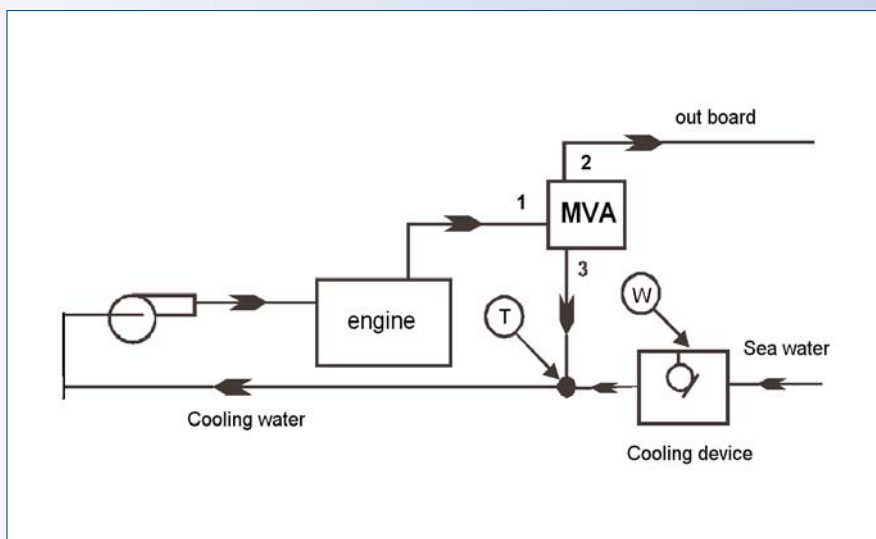

**Fig 4 COOLING WATER CONTROL BY MIXING**

Contrary to the system shown in Fig. 1 cold and warm water are mixed and the temperature will be maintained constant at the inlet of the engine. X serves, if necessary, for ventilation of the system. Another possibility for this kind of control is shown in Fig. 6

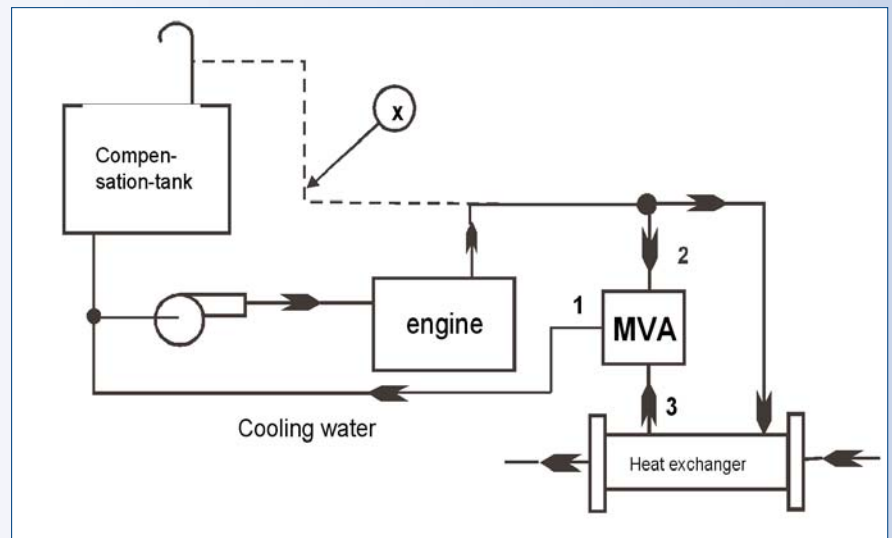

**Fig. 5 LUBRICATION OIL CONTROL BY SHORT-CIRCUIT (DIVERTING)**

In this scheme the MVA Thermostatic Valve is located in the lubrication oil circuit as a short-circuit controller. Similar as in Fig. 1 the temperature of the cooling water, in this scheme the temperature of the oil, that means the temperature of the oil at the outlet of the engine is maintained constant.

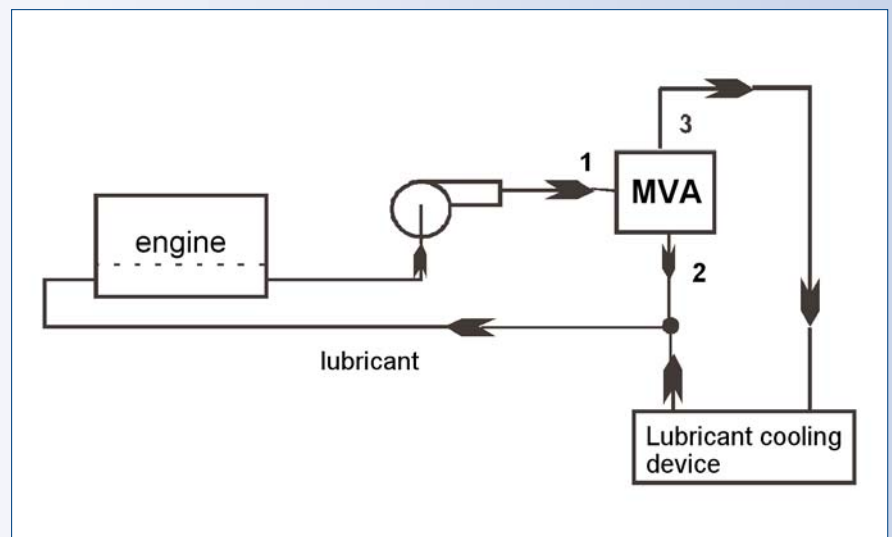

**Fig. 6 LUBRICATION OIL CONTROL BY MIXING**

In this system the MVA Thermostatic Valve mixes the warm oil coming from the engine with the cold one coming from the cooling device. This assures, that the temperature of the oil flow to the bearings, that means the temperature of the oil at the inlet of the engine will be maintained constant.

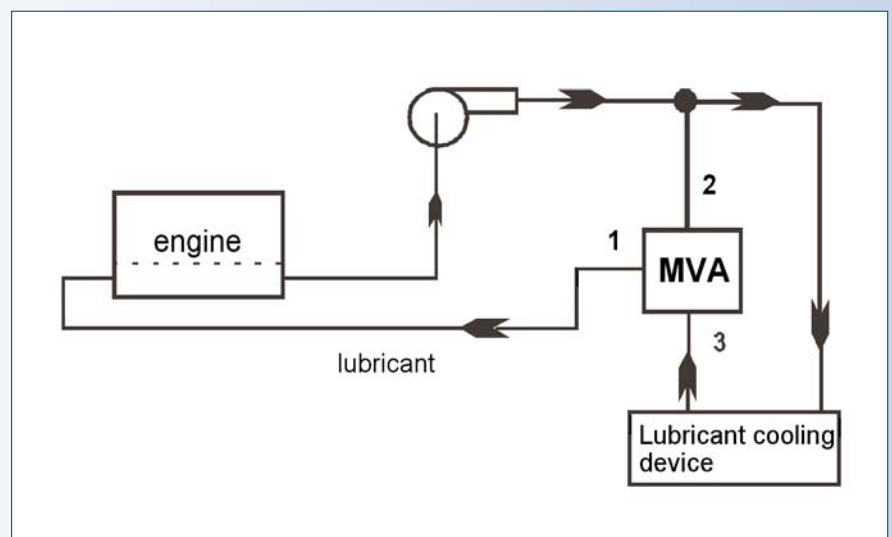

# CODE FOR THE MODELS M20 ... M40

## CODE FOR THERMOSTATIC VALVES MODEL M20 ... M40

M 25 C 1 A 120 C A

### type of thermostatic valve

M20, M20T, M25, M25T, M32J, M32T, M40J, M40T

### size of valve

M20, M20T : 3/4" /DN 20  
 M25, M25T : 1" /DN 25  
 M32J, M32T : 1 1/4" /DN 32  
 M40J, M40T : 1 1/2" /DN 40

### valve housing material

A = aluminium  
 B = bronze  
 C = cast iron EN GJL 250  
 D = spheroidal graphite cast iron EN GJS 400  
 E = stainless steel ASTM A351 CF- 8M  
 S = cast steel ASTM A216 WCB

### port connections

1 = BSP parallel  
 2 = BSP taper  
 3 = NPT  
 4 = flanges DIN 2501-1 PN 10  
 5 = flanges ANSI B16.5 (Class 150) RF  
 6 = flanges DIN 2501-1 PN 40  
 7 = flanges ANSI B16.5 (Class 300) RF  
 8 = flanges DIN 2501-1 PN 16

### type of element

A = 2040A standard, seal mat. Nitrile Rubber (BUNA N)  
 B = 2040 A standard, seal material Viton

valve size DN 40 there is a reduction possible

for example: M40TS5B175-30

### leak hole

A = no leak hole  
 B = 1 mm leak hole  
 C = 2 mm leak hole  
 D = 3 mm leak hole  
 E = 4 mm leak hole  
 X = without O-ring element

### special requirements

C = seat cast in body (standard)  
 D = bronze seat (special)  
 E = cast seat & leak hole in body  
 H = seat cast in body with kanigen plated element  
 23 = PTFE seals + kanigen plated element  
 30 = flow-reduction  
 38 = manual override

### nominal temperature of the elements no.

°F / °C	"cold"	"warm"
065/18	15	- 25°C
075/24	20	- 30
085/30	26	- 34
095/34	30	- 40
100/38	33	- 42
110/43	38	- 47
120/49	44	- 55
130/55	49	- 60
140/60	55	- 66
150/66	60	- 71
160/71	66	- 77
170/77	73	- 82
175/79	77	- 85
180/82	79	- 88
190/88	85	- 93
205/96	93	- 103
237/114	107	- 123

# TECHNICAL DATA MODELS M20 ... M40

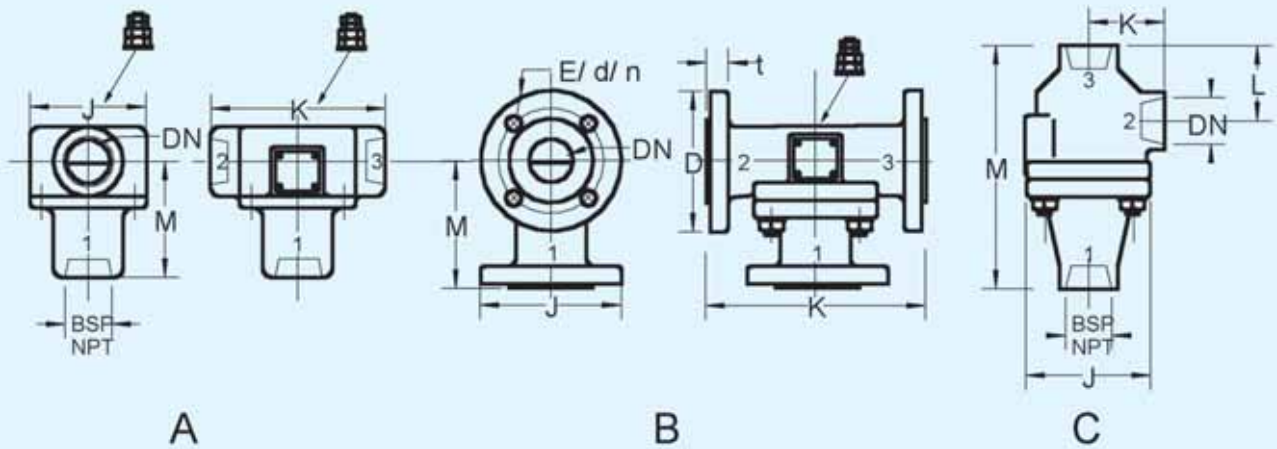

For the purpose of design engineering deviation of up to 10 mm should be respected. (Exact values on demand)

## Dimensions

DN	BSP NPT	A B C	J mm	K mm	L mm	M mm	t mm	PN10/16 D/E/d/n mm	PN25/40** D/E/d/n mm	125/150 lbs D/E/d/n mm	300 lbs** D/E/d/n mm
20	3/4"	C	87	61	50/56**	160/167**					
20T	3/4"	A	89	122		110					
20T		B	105/98,5*	178		101		105/75/18/4	105/75/18/4	98,5/70/16/4	117,5/82,5/19/4
25	1"	C	87	61	50/56**	160/167**					
25T	1"	A	89	122		110					
25T		B	105/98,5*	178		101		115/85/18/4	115/85/18/4	108/79,5/16/4	124/89/19/4
32	1 1/4"	C	87	73	39	160/167**					
40J	1 1/2"	C	87	73	39	160/167**					
40T	1 1/2"	A	96	156		96					
40T		B	150/127*	178		101	18	150/110/18/4	150/110/18/4	127/99/16/4	155,6/114,3/22/4

\*125/150 lbs

\*\*SS/CS

## Weights

DN	BSP NPT	A B C	CI DI kg	CS SS kg	Bz kg	Al kg
20	3/4"	C	2,15	2,2	2,2	2,1
20T	3/4"	A	3,1	3,3	3,3	
20T		B	7,7	7,7	9,1	4,8
25	1"	C	2,15	2,2	2,2	2,1
25T	1"	A	3,1	3,3	3,3	
25T		B	7,7	7,7	9,1	4,8
32	1 1/4"	C	3,0		3,2	2,1
40	1 1/2"	C	3,0		3,4	2,1
40	1 1/2"	A	4,1	4,1	4,9	4,2
40		B	7,7	7,7	9,1	4,8

## Flow Chart

delta p max. = 1,37 bar ( 20 p.s.i. )

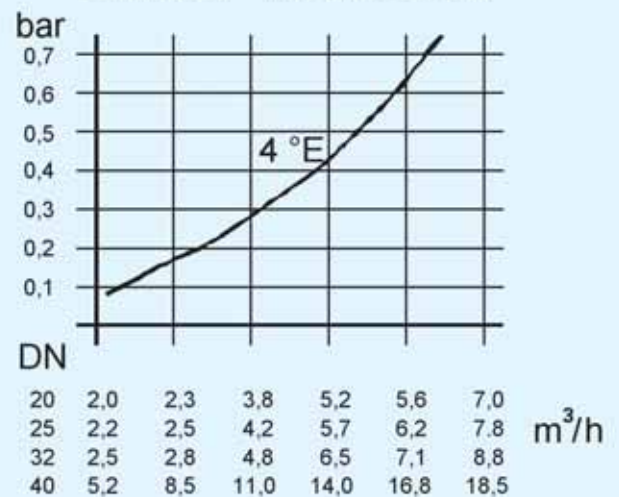

# CODE FOR THE MODELS M50 ... M150

## CODE FOR THERMOSTATIC VALVES MODEL M 50 ... M 150

M 80TC 2 G 120 D A

### type of thermostatic valve

M = standard with and without Manual override

### size of valve

~~DN 50H with 2" BSP~~  
 DN 50T with flanges  
 DN 65T with flanges  
 DN 80T with flanges  
 DN 100T with flanges  
 DN 125 with flanges  
 DN 150 with flanges

### valve housing material

A = aluminium  
 B = bronze  
 C = cast iron EN GJL 250  
 D = spheroidal graphite cast iron EN GJS 400  
 E = stainless ASTM A351 CF-8M  
 S = cast steel ASTM A216 WCB

### port connections flanges

1 = DIN 2501-1 PN 6  
 2 = DIN 2501-1 PN 10  
 3 = DIN 2501-1 PN 16  
 4 = ANSI B16.1 (Class 125) RF  
 5 = ANSI B16.5 (Class 150) RF  
 6 = DIN 2501-1 PN 25  
 7 = ANSI B16.5 (Class 300) RF  
 8 = DIN 2501-1 PN 40  
 B = BSP parallel

### type of element

G = 2001A standard for water and oil  
 H = 2012A standard with manual over ride  
 J = 2030A standard for salt water  
 L = 2030P kanigen plated  
 M = 2035P kanigen plated with manual override

Valve size DN 50 can be in housing model T (Fig. A, B) and F (Fig. C). Model T has in the coding the „T“ added.

for example: M50TC2G110DA

### leak hole

A = no leak hole  
 B = 2 mm leak hole  
 C = 4 mm leak hole  
 D = 6 mm leak hole  
 E = 8 mm leak hole  
 X = without O-ring element

### special requirements

D = standard - bronze seat  
 03 = special welding-connection  
 06 = alu-bronze housing  
 25 = PTFE seals  
 Others on request

### nominal temperature of the elements

no.	"cold"	"warm"
075 °F	= 24°C	21 °C - 29 °C
090	= 32	27 - 35
095	= 35	30 - 41
100	= 38	35 - 43
105	= 41	35 - 45
110	= 43	38 - 47
115	= 46	40 - 50
120	= 49	44 - 54
130	= 55	52 - 60
135	= 57	54 - 63
140	= 60	57 - 66
145	= 63	60 - 69
150	= 66	63 - 71
155	= 68	66 - 74
160	= 71	68 - 77
165	= 74	71 - 79
170	= 77	74 - 82
175	= 79	77 - 85
180	= 82	79 - 88
185	= 85	82 - 91
195	= 91	87 - 98
205	= 96	93 - 102
215	= 102	99 - 107
225	= 108	102 - 113
230	= 110	104 - 115
240	= 116	108 - 122

# TECHNICAL DATA MODELS M50 ... M150

10

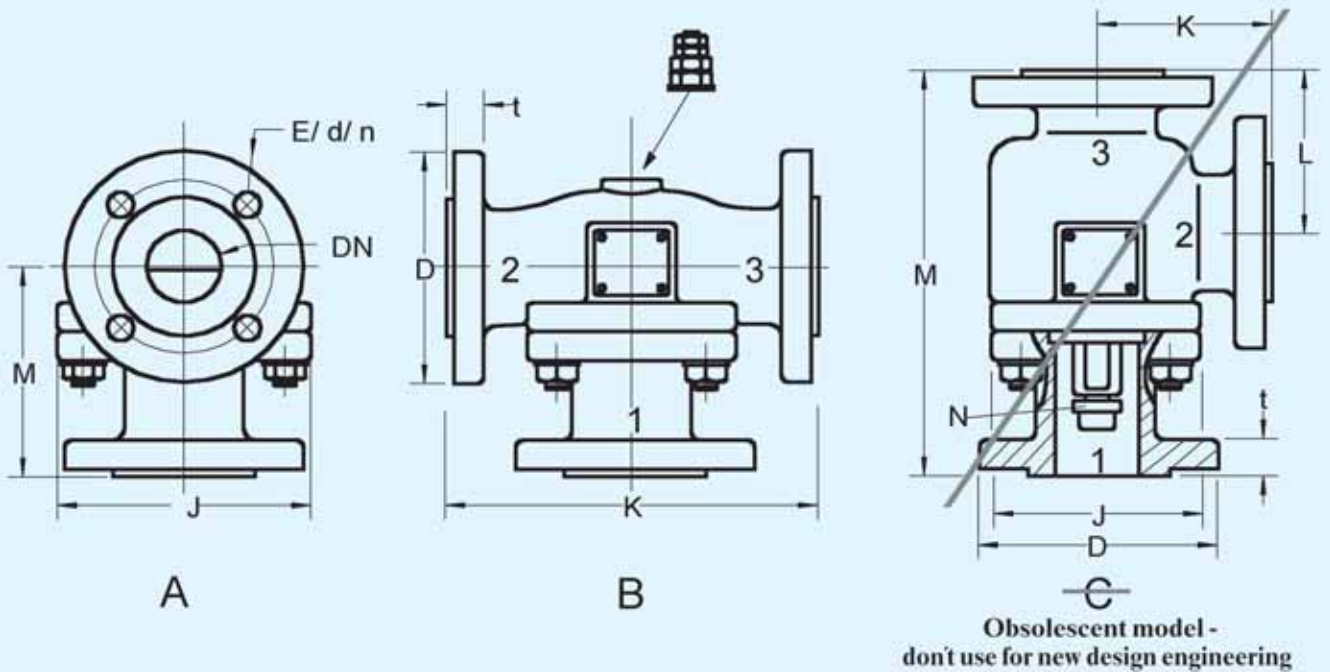

For the purpose of design engineering deviation of up to 10 mm should be respected. (Exact values on demand)

## Dimensions

DN	A	B	J	K	L	M	N	t	PN10/16 D/E/d/n	PN25/40** D/E/d/n	125/150 lbs D/E/d/n	300 lbs** D/E/d/n
	C		mm	mm	mm	mm	mm	mm	mm	mm	mm	mm
50	C		139	113	121	270	1	20	165/125/18/4	165/125/18/4	162,4/120,6/19/4	165/127/19/8
50	AB		140	225		150	1	20	165/125/18/4	165/125/18/4	152,4/120,6/19/4	165/127/19/8
65	AB		210	254/267*		165/171*	2	20	185/145/18/4	185/145/18/8	178/140/19/4	190,5/149/22,2/8
80	AB		210	267		171	2	22	200/160/18/8	200/160/18/8	190,5/152/19/4	203,6/168,3/22,2/8
100	AB		284	403/409*		217/220*	4	24	224/180/18/8	235/190/22/8	229/190,5/19/8	254/200/22,2/8
125	AB		349	489		241	6	26	254/210/18/8	270/220/26/8	254/216/22,2/8	279,4/235/22,2/8
150	AB		488	489		254	8	26	285/240/23/8	300/250/26/8	279,4/241,3/22,2/8	317,5/270/22,2/12
				*SS		*SS						

## Weights

DN	A	B	CI	CS	AI
	C		DI	SS	
	C		kg	kg	kg
50	C		18	20	7
50	AB		18	20	7
65	AB		24	31	10
80	AB		25	32	14
100	AB		60	60	24
125	AB		125	125	35
150	AB		136	136	48

## Flow Chart

delta p max. = 1,37 bar ( 20 p.s.i. )

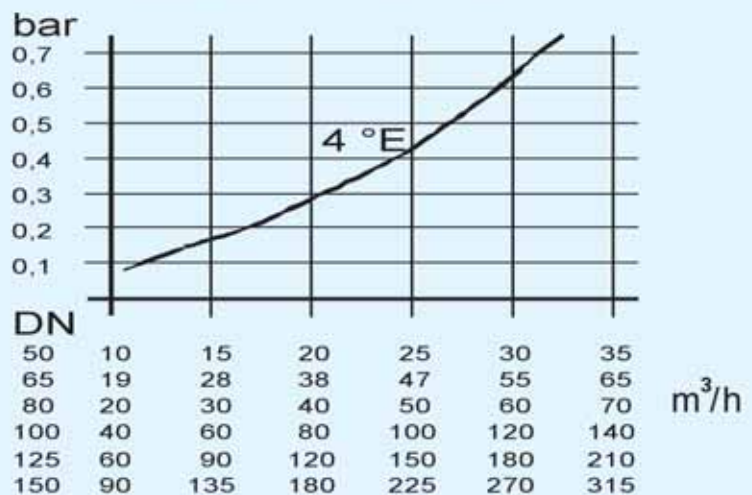

Subject to change without prior notice, issue Juli 2009